

CONTINUED SHEET 1

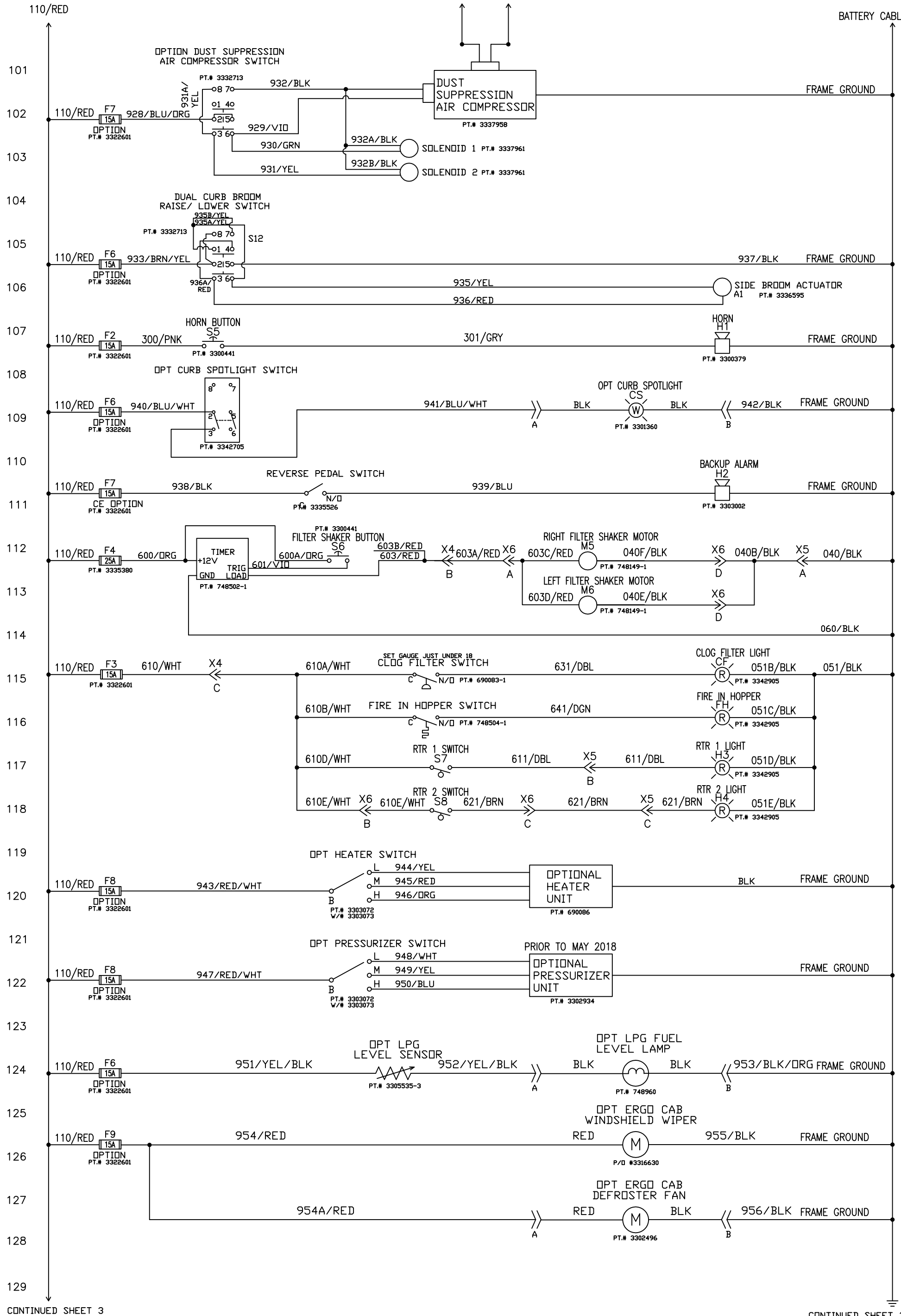

CONTINUED SHEET 3

CONTINUED SHEET 3

REV	ECN	DATE	DESCRIPTION	BY	PowerBoss® The Power of Clean		CONFIDENTIAL THIS DRAWING AND ALL INFORMATION CONTAINED HEREIN ARE THE EXCLUSIVE PROPERTY OF MINUTEMAN INTERNATIONAL, INC. THIS DRAWING IS NOT TO BE COPIED OR OTHERWISE REPRODUCED WITHOUT EXPRESSED WRITTEN PERMISSION OF MINUTEMAN INTERNATIONAL, INC. IN ADDITION, THIS DRAWING MUST BE RETURNED UPON REQUEST. FURTHER, ALL INFORMATION CONTAINED HEREIN MUST BE MAINTAINED CONFIDENTIAL.	TITLE	PART NUMBER	REVISION	PAGE NUMBER
B	MIN-13323	08/22/16	UPDATED SCHEMATIC- SEAT&NEUTRAL SWITCH	KHH	14N845 U.S. ROUTE 20 PINGREE GROVE, ILLINOIS 60140		DATE 5/3/10	SCHEMATIC-ELECTRICAL 9X GAS/LPG CE	3397502	E	2 OF 4
C	MIN-13574	10/02/17	ADDED BLUE SAFETY LIGHTS	KHH							
D	150297	06/11/18	ADDED MERV, LED LIGHTS & SHT 4	KHH							
E	150470	11/13/18	UPDATED MERV, PART #'S	KHH							
				ELECTRICAL DESIGN ENGINEER Jeff Pollack							